

UVMatrix™ 4X

Ultraviolet Air Disinfection Equipment

for outdoor, RTU and other HVAC system applications

Product information



UVMatrix™ 4X-Series

3 lamp lengths available

Model Number	No of Lamps	Lamp Length
UVMatrix™ 4X-112	1	12"
UVMatrix™ 4X-122	1	22"
UVMatrix™ 4X-133	1	33"

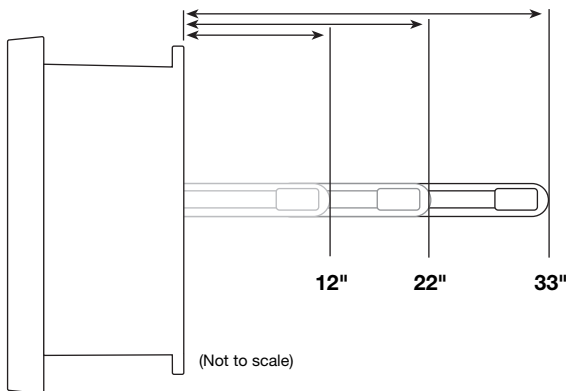

Available from:

Ultravation, Inc.
 218 Jones Drive
 P.O. Box 234
 Brandon, Vermont 05733
Toll Free 1-866-468-8247
 1-802-247-0034
 FAX 1-802-247-0033
www.ultravation.com

© 2003 ULTRAVATION, INC. 4X_SPECSHEET01.PDF / REV 062003

Benefits of Coil Irradiation

- Bio-growth prevention
- Allergy relief
- Efficiency optimization
- Elimination of coil cleaning as result of bio-contamination
- Airstream disinfection (residual)

UV eliminates mold on AC coils

Mold can be a serious problem for allergy sufferers, and a drain on HVAC efficiency and even cause property damage. Ultravation UVMatrix™ 4X UV systems are specially designed to install in outdoor HVAC air handlers. Their design reflects Ultravation's in-depth knowledge of ultraviolet light—and how it is optimized for HVAC coil disinfection.

UVMatrix™ 4X: Compact, NEMA 4X rated electrical cabinet

The 4X-Series is a compact, lightweight and easy-to-install design with no installation hardware to buy. The cabinets are fiberglass and weathertight for outdoor use. Two NEMA 4X knock-out plugs are included to accommodate connections for AC power and optional remote lamp operation monitoring (dry contacts provided standard).

T3™ Enhanced UV Lamps

The UVMatrix™ 4X-Series comes with 12", 22" or 33" Philips UV lamps that are enhanced with the Ultravation T3™ thermal optimization system, allowing much higher UV lamp output in cold HVAC air conditions. This design maximizes coil exposure, for more complete reduction or elimination of mold, and maximizes residual airstream disinfection. T3™ design allows lamps to be changed without removing or replacing the quartz glass thermal shield.

ESP™ Electronic-Smart Power

The Ultravation ESP™ power supply is auto-voltage sensing and operates at frequencies far exceeding a standard magnetic ballast. Its exceptional stability of voltage and current flow maximizes lamp output and lamp life. In a lamp-out situation, it automatically protects itself from an un-loaded condition. ESP™ simplifies installation still further, because with a single connection—regardless of voltage—the system automatically adjusts to voltages ranging from 120 to 277 VAC 50/60Hz with no step-down transformers or switches.

Additional features...

- Low power consumption
- Ultravation 360° UV dispersion means that a higher percentage of microbes will be eliminated in a single pass through the ultraviolet light.
- Safety Interlock System
- Dry contacts provided for use with optional remote lamp monitoring devices
- Lamp life expectancy 18,000 hrs (approx 24 months)
- Three year UV system warranty Covers entire unit except lamp(s).
- One year UV lamp warranty
- **Philips** premium UV lamps—the world's lowest mercury content lamp—less than 5mg per lamp.

Ultravation™
 Ultraviolet Technology

UVMatrix™ 4X

Ultraviolet Air Disinfection Equipment

for outdoor, packaged and other HVAC system applications

Specification Sheet

1. Scope of Supply

The outdoor rated UV equipment shall consist of a NEMA 4X fiberglass enclosure, UVC Lamp, quartz sleeve assembly, and an electronic power supply.

A. Power Supply Housing

- i. The power supply housing shall be NEMA 4X rated.
- ii. The power supply housing shall be lightweight and constructed of fiberglass.
- iii. All electrical connections shall be housed inside the power supply housing.
- iv. NEMA 4 rated knockout plugs shall be provided to prevent onsite housing modification.

B. UVC Lamps

- i. A UVC Lamp and a protective quartz sleeve assembly shall be utilized in cold air conditions to provide maximum thermal optimization of the germicidal UVC Lamps
- ii. The quartz sleeve assembly, when screwed into the back panel inside the power supply housing, shall have no wires or electrical connections exposed to the UV radiation, or the air handler internal environment.
- iii. The UVC Lamps shall be Slimline type, T5 diameter, 2G11 type base, and will produce broadband UVC of 250-260nm.
- iv. The UVC Lamps shall produce 85% of the initial UVC output at end of lamp life (9000 hours), or 80% of initial UVC output at extended life (18,000 hours).
- v. The UVC Lamps shall contain no more than 5 milligrams of mercury.

C. Electronic Power Supply

- i. Electronic power supplies shall operate on universal voltages from 120VAC to 277VAC at either 50 or 60Hz.
- ii. Electronic power supplies shall have a power factor of greater than 96%.
- iii. Maximum power consumption shall be no more than 0.50A @ 120V.

2. Installation:

- A. Determine a suitable location to install unit. Air handler or Ductwork should be of sufficient strength as to support the unit; otherwise reinforcement of the mounting location may be necessary.
- B. Mark hole location and using a 11/4" hole saw, cut 1 hole.
- C. Lift UVC equipment into place against air handler or ductwork. Fasten unit in place with self- tapping screws or standard hardware.
- D. Install the quartz assembly by inserting it into unit and screwing into back panel until hand tight against enclosure. Slide lamp into quartz assembly. Push socket onto lamp base.
- E. Make electrical connections. THIS SHOULD BE DONE IN ACCORDANCE WITH ALL STATE AND LOCAL ELECTRICAL AND BUILDING CODES.
- F. Turn on unit and inspect operation.

3. Optional Equipment:

- A. UVC lamp monitor – Provided with dry contacts to indicate lamp operation status.
- B. UVC intensity monitor – 0-100% meter, measuring 254nm UVC, includes dry contacts that switch state when adjustable set point is reached.