

UVMatrix™ AS

Airstream Disinfection Equipment

for Commercial HVAC Systems

Specification Sheet

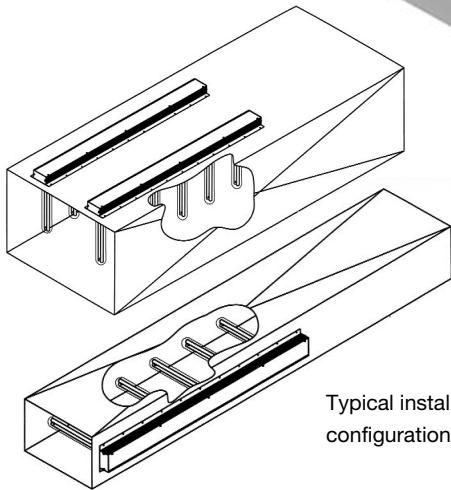

Typical installation configurations

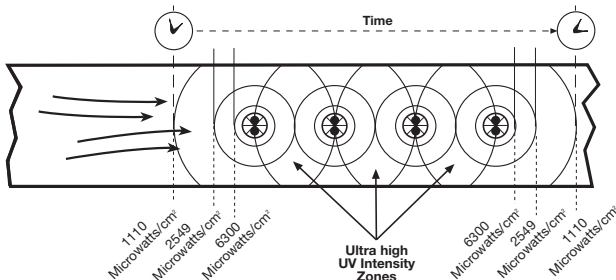

The number of microorganisms inactivated in a single pass is dependent on the time of exposure to UV. **Ultravation 360° UV dispersion** means that a higher percentage of microbes will be eliminated in a single pass through the ultraviolet light. Lamp spacing is calculated to optimize exposure. Then, as air is re-circulated through the HVAC system, surviving organisms receive additional ultraviolet exposure.

Available from:



Air Duct Mounted Accessory Classified By Underwriters Laboratories Inc. with Respect to Electric Shock, Fire and Casualty Hazards Only

Ultravation, Inc.

218 Jones Drive
P.O. Box 234

Brandon, Vermont 05733

Toll Free 1-866-468-8247

1-802-247-0034 FAX 1-802-247-0033

www.ultravation.com

© 2003 ULTRAVATION, INC. AS_SPECSHEET.PDF / REV 062003

Benefits of airstream disinfection

- Improvement of indoor air quality by reducing of airborne pathogens
- Allergy relief
- Odor reduction (when due to bio-contamination)

UV can substantially reduce the spread of airborne illness

Indoor air that is continuously re-circulated through 254nm UV light will show a dramatic reduction in the count of bacteria and other microorganisms. Ultravation **UVMatrix™ AS** equipment for commercial HVAC systems, is designed specifically for airstream disinfection, with design emphasis placed on achieving a balance between intensity and exposure time. Their design reflects Ultravation's in-depth knowledge of ultraviolet light—and how it is optimized for airstream applications.

UVMatrix™ AS— Easy to configure for any HVAC installation

UVMatrix™ AS systems have lamp arrays engineered to optimize disinfection capability, and can be installed in single or multiple unit configurations.

Philips Compact Twin UV Lamps with T3™ enhanced performance

Airstream disinfection requires higher UV intensities due to short micro-organism exposure times. The UVMatrix™ AS series UV lamp design uses Philips patented Compact-Twin UV lamps, which provide the highest UV intensity for small areas (such as HVAC ducts). Ultravation T3™ design, further enhances UV performance by enclosing the lamps in UV transparent quartz, which optimizes lamp temperature. This increases UV intensity under typical operating conditions by approximately 40%. The result is unprecedented disinfection performance for HVAC airstream applications! T3™ performance is very cost effective because new UV lamps can be installed without replacing the quartz sleeves—minimizing re-lamping costs. This not only makes lamps easy to change, the T3™ quartz sleeve system remains sealed, so there is no loss of air pressure during lamp changes.

ESP™ Electronic-Smart Power

UVMatrix™ AS systems utilize discrete ESP™ electronic auto-voltage sensing power supplies with no more than two lamps per power supply module—eliminating the possibility of complete loss of disinfection due to UV system trouble. An optional set of remote alarm contacts will help protect against an extended lamp-out condition. ESP™ optimizes lamp performance because it operates at frequencies far exceeding a standard magnetic ballast. Its exceptional stability of voltage and current flow optimizes both lamp output lifespan. In a lamp-out situation, it self protects from an un-loaded condition.

Auto-voltage sensing

ESP™ furthers simplicity in installation with a single connection—regardless of voltage—the system automatically adjusts to voltages ranging from 120 to 277 VAC 50/60Hz with no step-down transformers or switches.

Additional features...

- Low power consumption
- Long lamp life expectancy: 18,000 hrs (approx 24 months)
- Three-year UV system warranty
- One-year UV lamp warranty
- Philips premium UV lamps—with less than 5mg per lamp, the world's lowest mercury content UV lamp.

Ultravation™
Ultraviolet Technology

UVMatrix™ AS

Airstream Disinfection Equipment for Commercial HVAC Systems

Specification Sheet

1. Scope of Supply

The airstream irradiation equipment shall consist of UVC Lamps, quartz sleeve assemblies, electronic power supplies, and aluminum power supply housing. The equipment shall have a replaceable fuse, on/off toggle switch and a 3/8" conduit connector for the customer power supply.

A. UVC Lamps

- i. A lamp and protective quartz sleeve assembly shall be utilized in cold air conditions to provide maximum thermal optimization of the germicidal UVC Lamps.
- ii. The lamp shall be able to be changed out independent of the protective quartz sleeve assembly without depressurizing the air conditioning system.
- iii. The UVC lamps shall be hot cathode type, twin-tube, 2G11 type base, and will produce broadband UVC of 250-260nm.
- iv. The UVC lamps shall produce 85% of the initial UVC output at end of lamp life (9000 hours), or 80% of initial UVC output at extended life (18,000 hours).
- v. The UVC lamps shall contain no more than 5 milligrams of mercury.

B. Electronic Power Supply

- i. Electronic power supplies shall operate on universal voltages from 120VAC to 277VAC at either 50 or 60Hz.
- ii. Electronic power supplies shall have a power factor of greater than 96%.
- iii. Maximum current for each model shall be as follows:

Model Number	AS-4/9	AS-4/16	AS-4/20	AS-6/9	AS-6/16	AS-6/20
Maximum Current @ 120V	0.94A	1.42A	2.84A	1.41A	2.13A	4.26A

C. Aluminum Power Supply Housing

- i. All electrical connections shall be housed inside the power supply housing.
- ii. The power supply housing shall be of low profile and have integral mounting flange on each side of the housing total length. The mounting flange shall be provided with spaced mounting holes to be fastened to the duct work with hardware provided.

2. Installation

- A. Power supply housing shall be mounted on duct work and located preferably on supply side of air conditioning.
- B. A series of 2 1/2" holes are required to be predrilled into the duct work (quantity dependent on UV equipment needed).
- C. Power supply housing shall be mounted on duct work and screwed into place.
- D. Power connections to be terminated to terminal strip located inside the power supply housing.

3. Optional Equipment

- A. UVC lamp monitor—Provided with dry contacts to indicate lamp operation status.
- B. Safety Interlock Power Switch located on cover of aluminum to disengage power to lamps when equipment cover is removed.
- C. UVC intensity monitor—0-100% meter, measuring 254nm UV, includes dry contacts that switch state when adjustable set point is reached. A 4-20ma signal shall also be provided for remote monitoring.